

MCV - MCH - MCHZ

Multistage pumps

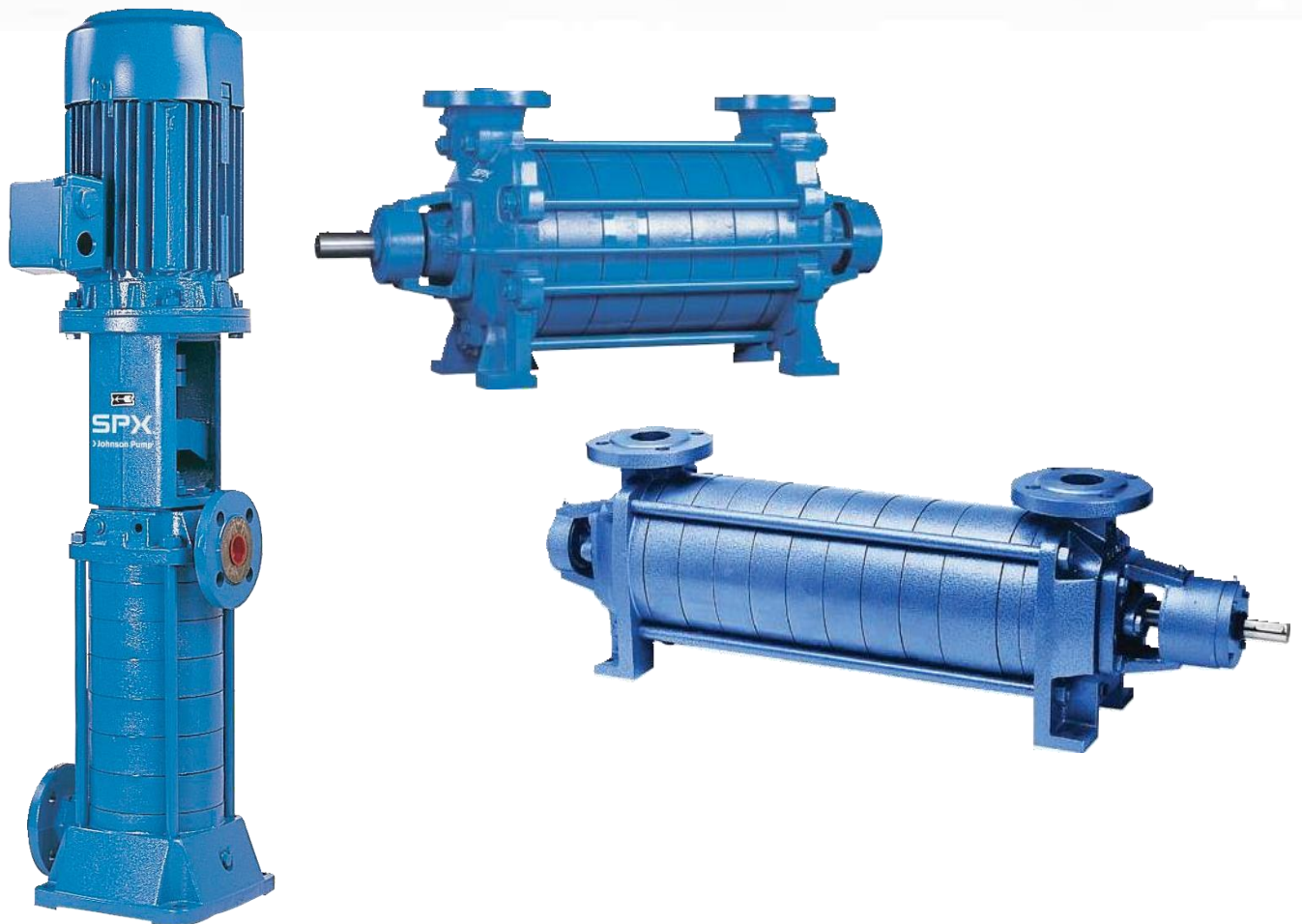

MStella Projects is a privately owned company dedicated to fostering true and meaningful partnerships across all industries.

We don't limit ourselves - we connect, develop, and grow partnerships that bring value to a diverse range of clients and partners. By delivering effective solutions, we ensure mutual success.

A 100% Black Women owned Level 1 B-BBEE accredited company, MStella Projects is established and managed by its founding member, Meghan Smith.

Meghan has experience across various industries, leveraging her expertise to cultivate strong partnerships that benefit all involved. Our unique company structure empowers surrounding communities.

The partnerships we forge prioritize collaboration and shared success, ensuring a positive impact that extends beyond just business transactions

Based in Cape Town, South Africa, MStella Projects is a multi-industry Third-Party leader. The company's highly-specialized, engineered products and technologies serve customers in three primary strategic growth markets: infrastructure, process solutions and diagnostic systems.

Many of MStella Projects' innovative solutions are playing a role in helping to meet rising global demand; particularly in emerging markets for processed foods & beverages, mining industries, construction industry, agricultural industry, oil and gas industry and the renewable energy sector. The company's products include thermal heat transfer equipment for power plants; power transformers for utility companies; process equipment for the food & beverage industry.

For more information,

visit: <http://www.mstella.co.za>

You can put pressure on them!

We offer you a range of reliable high-pressure multistage pumps. It includes a series of horizontal pumps, MCH and a series of vertical pumps, MCV. The horizontal types can also be supplied in a self-priming version, MCHZ ..

The pumps consist of an inlet and outlet casing and a number of stages in between them. Each basic type is designed with a number of pressure stages. A pressure stage consists of radial diffuser channels and a matching impeller.

Flange dimensions, bolt circle and number of holes are according DIN 2535 ND 40.

The horizontal pumps are driven by a standard IEC foot motor. The vertical pumps are driven by a standard IEC flange motor, which is connected to the lantern piece of the pump. A fitting edge ensures that alignment is not required. For all pumps the power is transmitted through a flexible coupling.

Due to the modular design there is a high level of interchangeability of parts between the multi-stage pump types.

Shaft sealing options available are mechanical seals as well as gland packing.



Multi-stage pump types

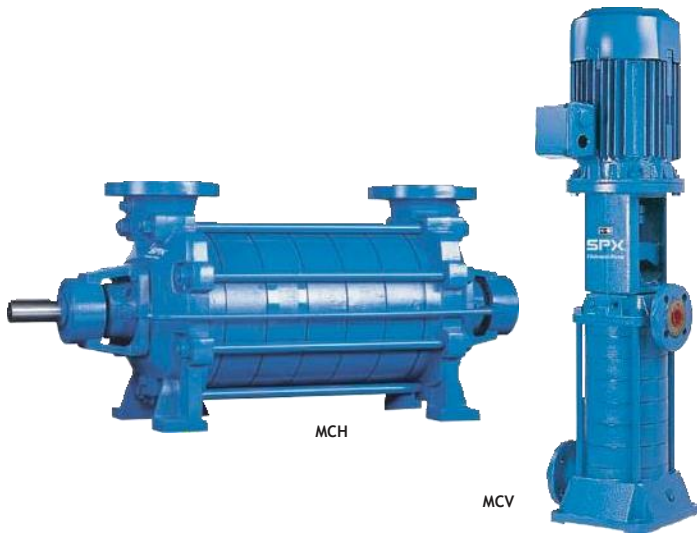

TYPICAL CHARACTERISTICS

- Rigid, reliable construction
- Available in cast iron and bronze
- High pump efficiency
- Suitable for a wide range of duties
- Low maintenance cost
- Including a self-priming version
- Shaft sealing by means of mechanical seal or gland packing

TECHNICAL DATA	
MAX. CAPACITY	100 M ³ /H
MAX. HEAD	340 M
MAX. WORKING PRESSURE	40 BAR, MINUS 3 x IN LET PRESSURE
MAX. TEMPERATURE	-20 °C / + 150 °C
MAX. SPEED	3600 RPM

Typical product applications

Proven quality all over the place!

UTILITY

Multistage pumps are used for pressure booster sets for water supply in high rise buildings. They are used for sinking piles by water injection on building projects. Other main duties comprise fire fighting units.



GENERAL INDUSTRY

In general industry typical applications are pumping of condensate and boiler feeding, circulation of hot water or cooling water.



SHIP BUILDING

Multistage pumps can handle fresh water as well as sea water, both clean and slightly contaminated. Their compact, space saving build makes them ideal pumps for engine rooms and general duties.



Features and benefits

BEARING HOUSING

- fitted with 2 apertures
- easily accessible gland housing

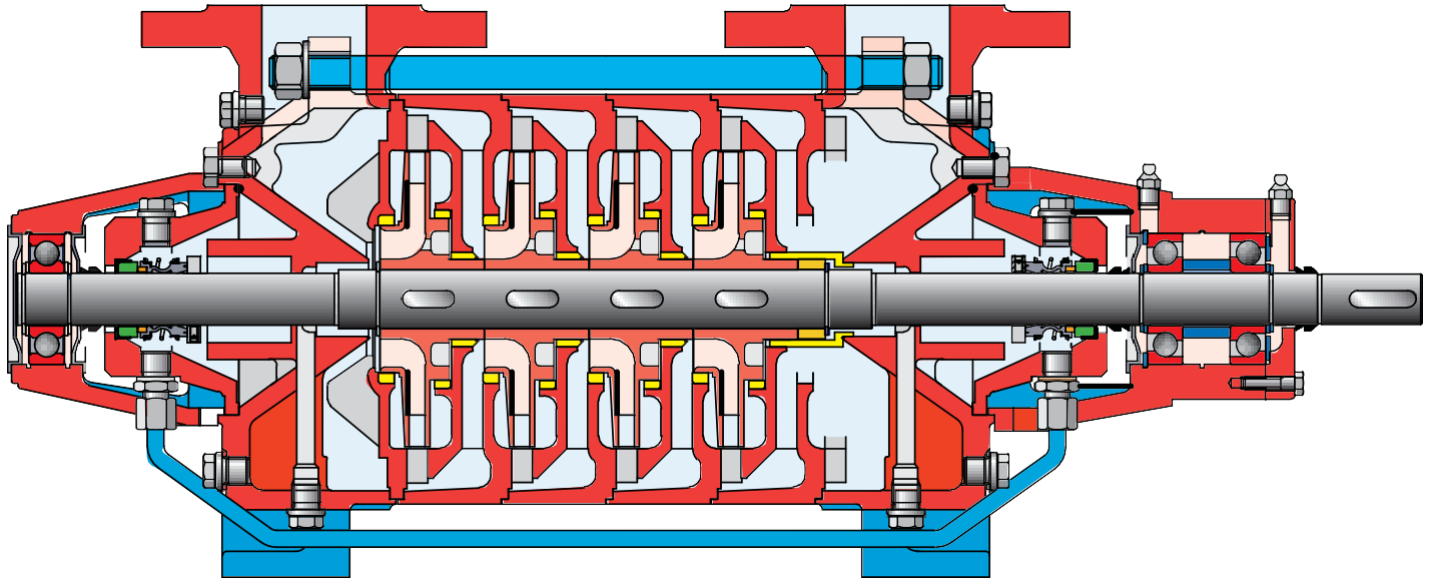

MCH

MCH FEET

- pump casing support in vertical centre line with flange and piping
- optimal distribution of forces

WEARRINGS

- on all stages casing wearings are applied
- increased maintainability

MCHZ SELF- PRIMING SECTION

- contains a built-in vacuum pump
- operates according to the liquid ring principle
- always ready for immediate duty
- good air and gas handling, discharged immediately via the pressure pipe

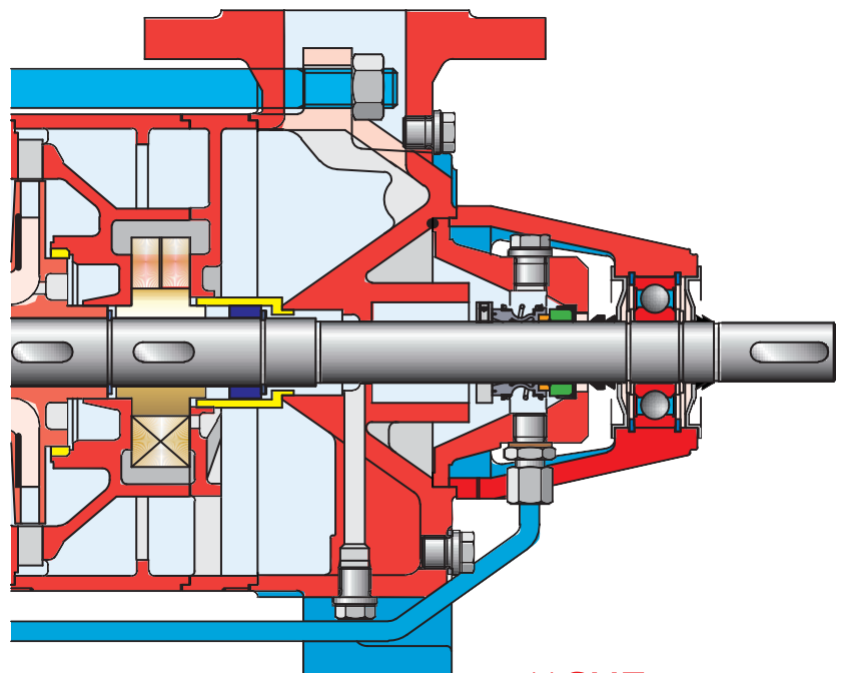

MCHZ

PUM P CASI NGS

- cast flanges on suction and pressure casing
- cast foot on MCV suction casing
- fitted with connections for pressure gauge, balance line, possible barrier liquid and drain
- *versatile casing design*
- *very rigid and durable construction*
- *exact positioning in pipework*

SU CTI ON COVE R

- with 2 anti-rotation vanes located in front of the first impeller
- *prevents for turbulence at impeller entry*
- *better NPSHr values*

IM PE L L E R S

- closed impellers
- designed with 2 sealing edges and balance holes
- *better hydraulic performance*
- *axial forces reduced to a minimum*

BEA R I N G

- axially mounted bearing
- *absorbing the remaining axial thrust*

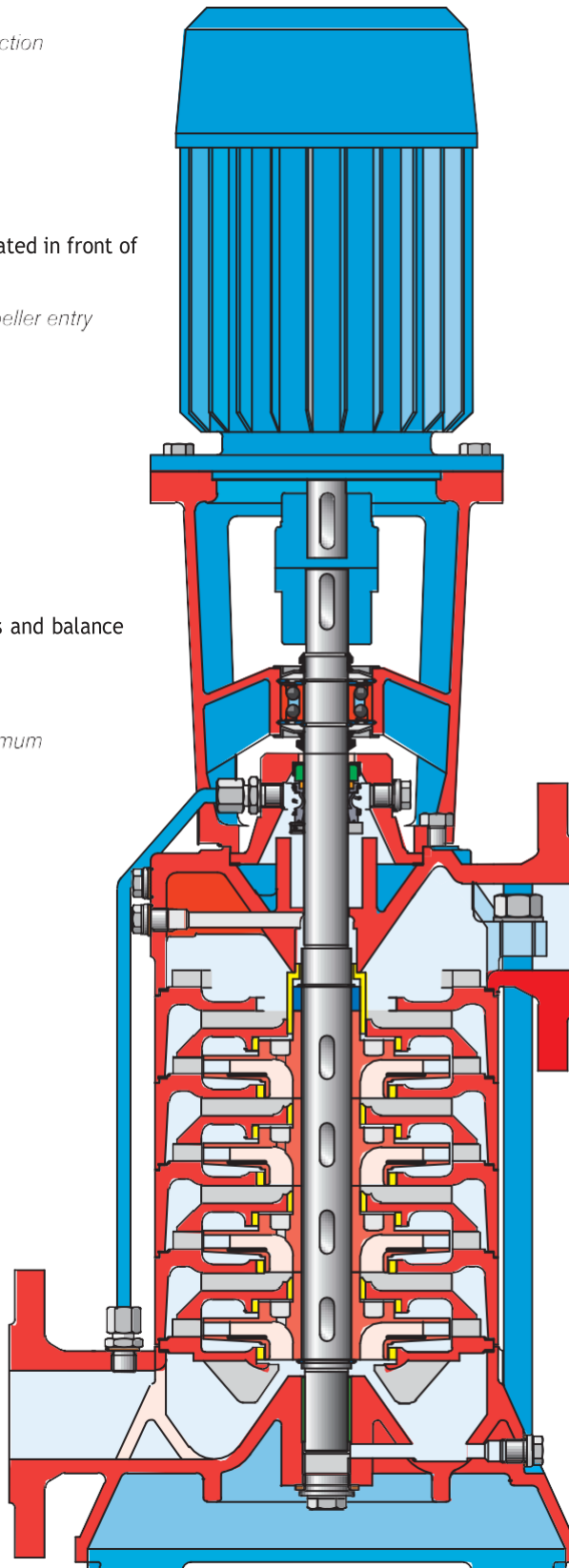

STAG E CASI NGS

- fitted with exchangeable wear rings
- with radial diffusors
- *longer pump life*
- *minimal radial forces resulting in low vibration*

MCV CONN ECTI ON

- pressure flange can be fitted in 4 ways
- *versatile connection possibilities*

MCV SLID E BEA R I N G

- lubricated by the pumped liquid
- fitted in the inlet casing
- *requires no maintenance*

MCV

Shaft sealing

Shaft sealing is available in two variants:

- Standardized gland packing rings. When the pressure in the gland becomes too high the pumps are provided with a balance pipe. For the horizontal pump types a water cooled stuffing box is optional.
- Mechanical seal with bellows. Cooling and lubrication of this seal is achieved by circulation of the pumped liquid via a balance pipe.

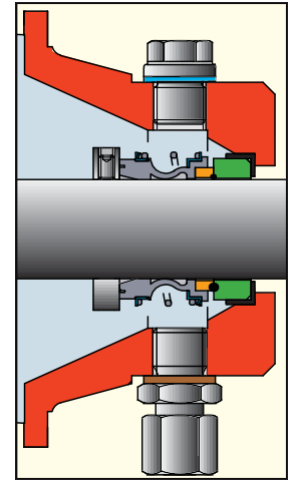
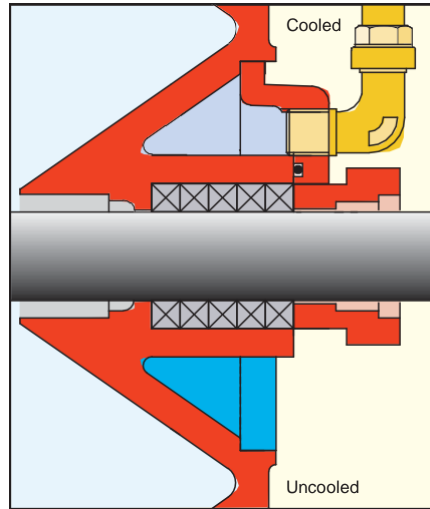
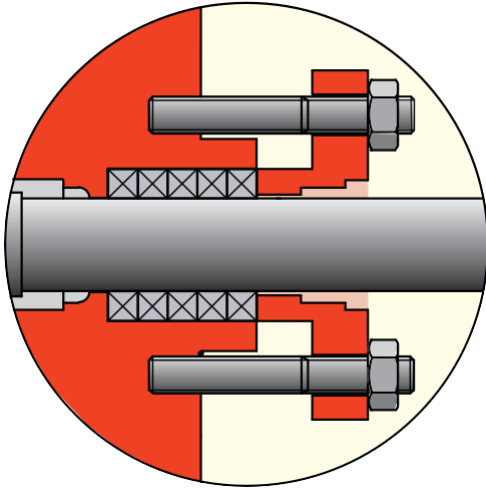

Bearing

- The horizontal pumps are designed with 2 deep-groove ball bearings. The largest types have a double-row angular contact bearing on pressure side. MCH 14 can be supplied with a reinforced bearing, consisting of 2 singlerow angular contact bearings on pressure side. The bearing on pressure side is axially fixed.
- The vertical types are fitted with a double-row angular contact bearing which is axially fixed in the lantern piece. MCV 16 has a deep groove ball bearing.
- All bearings are grease-lubricated.
- In the suction casing the MCV types have a slide bearing, lubricated by the pumped liquid.

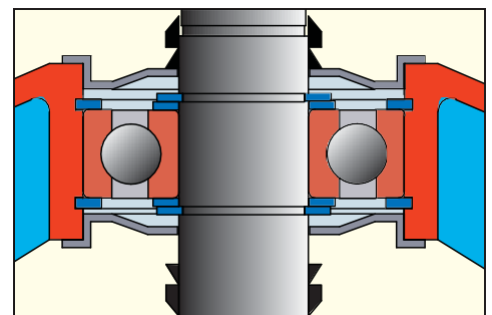
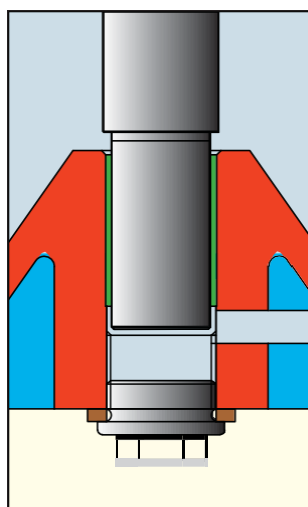
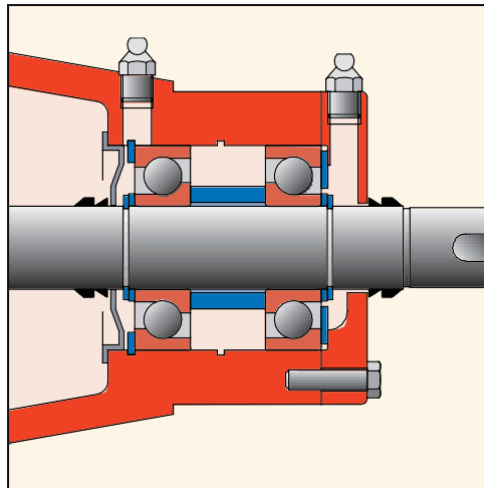

Performance

- = limits MCV
- = limits MCH
- = limits MCHZ

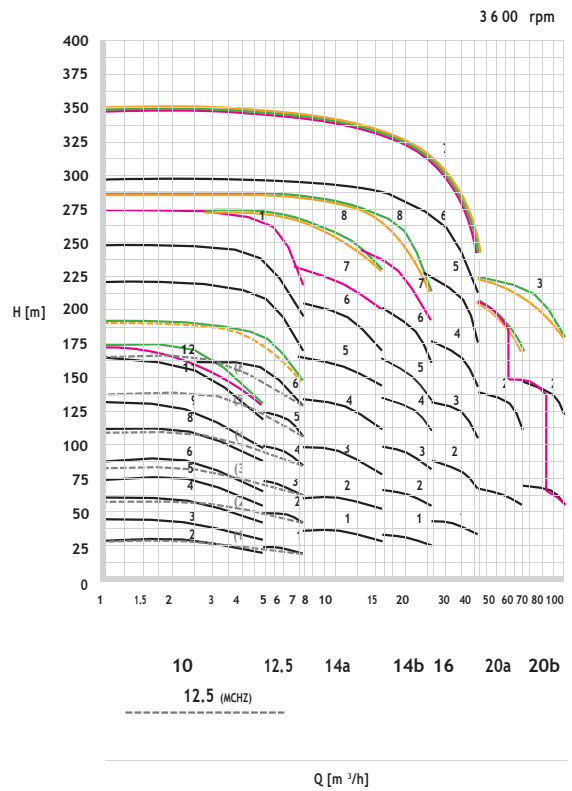
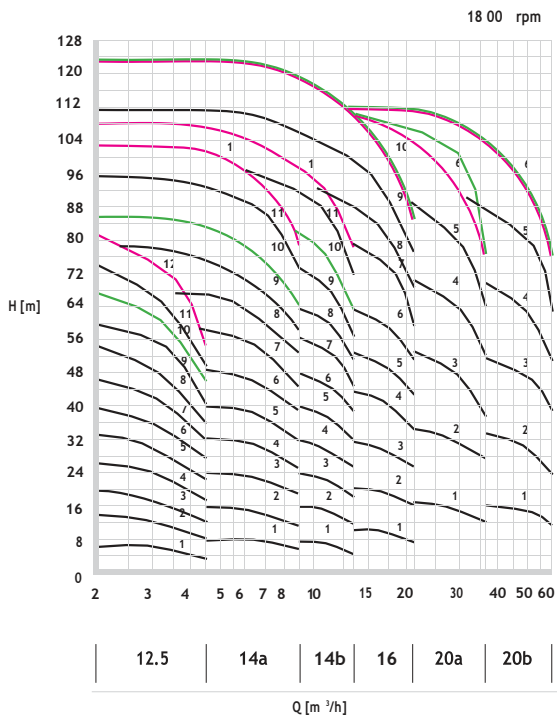
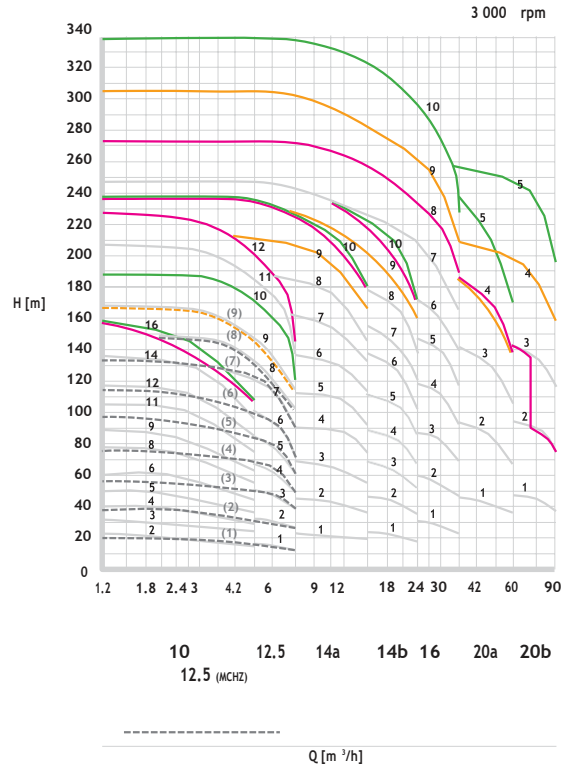
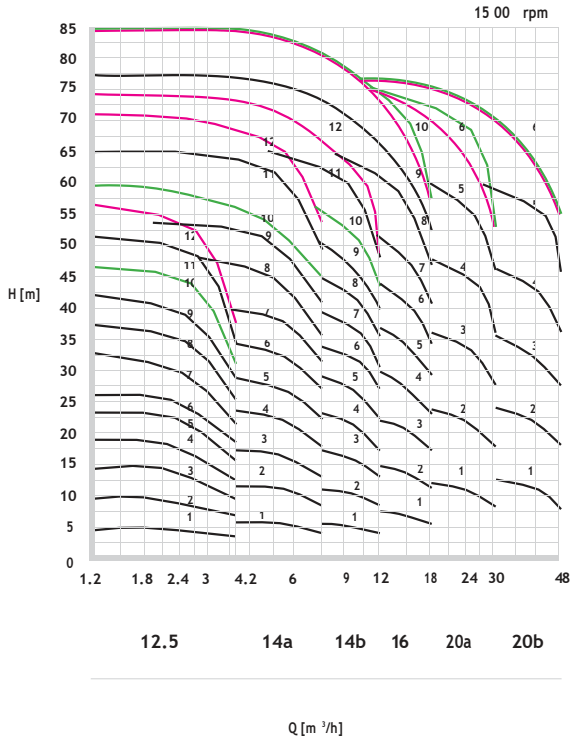

MCV - MCH - MCHZ



Create. Enhance. Sustain. Driven by passion!

Multistage pumps

MStella Projects [PTY] LTD.

Cape Town, South Africa

T: +27 (0)82 455 9878

E: info@mstella.co.za

MStella Projects reserves the right to incorporate our latest design and material changes without notice or obligation.

Design features, materials of construction and dimensional data, as described in this bulletin, are provided for your information only and should not be relied upon unless confirmed in writing. Please contact your local sales representative for product availability in your region. For more information visit www.mstella.co.za